

# Acadian House Kitchen & Bath Studio

12888 Jefferson Hwy.  
Baton Rouge, La. 70816

Designer: \_\_\_\_\_

## Bath Design Survey Form

Date:
Name:
Residence:
Jobsite Address:

Client 1:
Home Phone:
Work Phone:
Cell Phone:
Email:

Client 2:
Home Phone:
Work Phone:
Cell Phone:
Email:

Appointment
Schedule:
Call When Ready:
Times Available:
Directions:

Allied Professional
Name:
Firm:
Address:
Office Phone:
Cell Phone:
Email:

Notes: \_\_\_\_\_

\_\_\_\_\_

\_\_\_\_\_

\_\_\_\_\_

\_\_\_\_\_

# General Client Information

1. *What type of project is this?* Renovation New Construction
2. *Have you ever purchased a bathroom before?* Yes No
3. *When would you like to start the project?* \_\_\_\_\_ Complete the Project? \_\_\_\_\_
4. *How much time do you / will you spend at the jobsite residence?* \_\_\_\_\_
5. *How did you learn about our firm?* \_\_\_\_\_
6. *Has anyone else assisted you in preparing a design for the bath?* \_\_\_\_\_
7. *Do you plan on retaining an interior designer or architect to assist in the bath planning?*  
If so, Name: \_\_\_\_\_ Phone: \_\_\_\_\_
8. *Do you have a specific builder / contractor or other subcontractor / specialist with whom you would like to work?*  
If so, Name: \_\_\_\_\_ Phone: \_\_\_\_\_
9. *What portion of the project, if any, will be your responsibility?* \_\_\_\_\_
10. *What budget range have you established for your bath project?*  
\$5,000–\$10,000 \$10,000–\$20,000 \$20,000–\$30,000 \$30,000–\$50,000 \$50,000–\$60,000 \$60,000–\$75,000   
\$75,000+
11. *How long do you intend to own the jobsite residence?* \_\_\_\_\_  
a. Is return on investment a primary concern? \_\_\_\_\_  
b. Do you plan on renting the jobsite residence? \_\_\_\_\_
12. *What family members will share in the final decision-making process?* \_\_\_\_\_
13. *Would you like our firm to assist you in securing project financing?* Yes No
14. *What do you dislike most about your present bath?* \_\_\_\_\_  
\_\_\_\_\_
15. *What do you like most about your present bath?* \_\_\_\_\_  
\_\_\_\_\_
16. *Sustainable design ideas important to your family:*

<input type="checkbox"/> Use of "Green" Products	General products made from recycled materials: <input type="checkbox"/> Cabinets <input type="checkbox"/> Counters <input type="checkbox"/> Floors <input type="checkbox"/> Walls <input type="checkbox"/> Building Materials
	<input type="checkbox"/> Wood products supplied by environmentally responsible manufacturers _____
<input type="checkbox"/> Water usage:	<input type="checkbox"/> Sustainable design details incorporated into the plan
<input type="checkbox"/> Water efficient fixtures: <input type="checkbox"/> Toilet <input type="checkbox"/> Bathtub <input type="checkbox"/> Shower	
<input type="checkbox"/> Energy efficient lighting systems:	
17. *If you are remodeling:* Is there a room addition planned? Yes No  
a. When was the house built? \_\_\_\_\_ How old is the present bath? \_\_\_\_\_  
b. Are you considering relocating windows doors walls in your new plan?
18. *If you are building a new home:*  
a. Are you able to relocate windows doors walls at this stage of construction? Yes No  
b. Are you able to relocate walls at this stages of construction Yes No
19. *Is there a view from the bathroom to be considered:* Yes No  
a. Sun exposure \_\_\_\_\_  
b. From where in the bathroom should the view be visible? Bathtub Vanity Shower Other \_\_\_\_\_  
c. What about privacy? \_\_\_\_\_

# Specific Bath Questions

1. *Is this a*  Master  Children  Other Family Member  Guest  Special Area: \_\_\_\_\_ *bathroom?*
2. *How many bathrooms are in the home?* \_\_\_\_\_
3. *Who will use the bathroom?* \_\_\_\_\_
4. *Characteristics of family members who use the bathroom:* Are you planning on enlarging your family while living here?  Yes  No

Name	Age	Handed	Height	Physical Limitations/Mobility Aids
1.		<input type="checkbox"/> R <input type="checkbox"/> L		
2.		<input type="checkbox"/> R <input type="checkbox"/> L		
3.		<input type="checkbox"/> R <input type="checkbox"/> L		
4.		<input type="checkbox"/> R <input type="checkbox"/> L		
5.		<input type="checkbox"/> R <input type="checkbox"/> L		

5. *Personal Information about the bathroom:*
  - a. Will more than one person be using the bathroom at the same time? \_\_\_\_\_ How often? \_\_\_\_\_
  - b. What types of bathroom activities can be done in a shared bathroom space? \_\_\_\_\_
  - c. What types of bathroom activities need to be done in private? \_\_\_\_\_
  - d. How important is auditory privacy? \_\_\_\_\_ Are bathroom noises a problem? \_\_\_\_\_
6. *Visitability:*
  - a. Will this bathroom be used by visitors to the home?  Yes  No How often? \_\_\_\_\_
  - b. Will the visitors be children or adults? \_\_\_\_\_
  - c. Do any regular or frequent visitors have any physical limitation? \_\_\_\_\_
7. *Do you prefer separate showering and bathing areas?* \_\_\_\_\_
8. *Would you like to consider a tub that will accommodate more than one person?* \_\_\_\_\_
9. *Would you like to consider a shower that will accommodate more than one person?* \_\_\_\_\_
10. *Do you prefer the water closet and/or bidet be separate from the other fixtures, and placed in its own compartment?* \_\_\_\_\_
11. *Checklist for Bathroom activities:*

Grooming Activities		Location					Person		
		Vanity / Lavatory	Dressing Table	Bathub	Shower	Other Room	Person #1	Person #2	Person #3
<b>Body:</b>	Washing	<input type="checkbox"/>	<input type="checkbox"/>	<input type="checkbox"/>	<input type="checkbox"/>	<input type="checkbox"/>	<input type="checkbox"/>	<input type="checkbox"/>	<input type="checkbox"/>
	Shave - Face	<input type="checkbox"/>	<input type="checkbox"/>	<input type="checkbox"/>	<input type="checkbox"/>	<input type="checkbox"/>	<input type="checkbox"/>	<input type="checkbox"/>	<input type="checkbox"/>
	Shave - Body	<input type="checkbox"/>	<input type="checkbox"/>	<input type="checkbox"/>	<input type="checkbox"/>	<input type="checkbox"/>	<input type="checkbox"/>	<input type="checkbox"/>	<input type="checkbox"/>
	Apply Lotion	<input type="checkbox"/>	<input type="checkbox"/>	<input type="checkbox"/>	<input type="checkbox"/>	<input type="checkbox"/>	<input type="checkbox"/>	<input type="checkbox"/>	<input type="checkbox"/>
	Hair washing	<input type="checkbox"/>	<input type="checkbox"/>	<input type="checkbox"/>	<input type="checkbox"/>	<input type="checkbox"/>	<input type="checkbox"/>	<input type="checkbox"/>	<input type="checkbox"/>
<b>Teeth:</b>	Brush	<input type="checkbox"/>	<input type="checkbox"/>	<input type="checkbox"/>	<input type="checkbox"/>	<input type="checkbox"/>	<input type="checkbox"/>	<input type="checkbox"/>	<input type="checkbox"/>
	Floss	<input type="checkbox"/>	<input type="checkbox"/>	<input type="checkbox"/>	<input type="checkbox"/>	<input type="checkbox"/>	<input type="checkbox"/>	<input type="checkbox"/>	<input type="checkbox"/>
<b>Nails:</b>	Finger	<input type="checkbox"/>	<input type="checkbox"/>	<input type="checkbox"/>	<input type="checkbox"/>	<input type="checkbox"/>	<input type="checkbox"/>	<input type="checkbox"/>	<input type="checkbox"/>
	Toe	<input type="checkbox"/>	<input type="checkbox"/>	<input type="checkbox"/>	<input type="checkbox"/>	<input type="checkbox"/>	<input type="checkbox"/>	<input type="checkbox"/>	<input type="checkbox"/>
<b>Cosmetics:</b>	Apply	<input type="checkbox"/>	<input type="checkbox"/>	<input type="checkbox"/>	<input type="checkbox"/>	<input type="checkbox"/>	<input type="checkbox"/>	<input type="checkbox"/>	<input type="checkbox"/>
	Remove	<input type="checkbox"/>	<input type="checkbox"/>	<input type="checkbox"/>	<input type="checkbox"/>	<input type="checkbox"/>	<input type="checkbox"/>	<input type="checkbox"/>	<input type="checkbox"/>
<b>Face:</b>	Skin Care	<input type="checkbox"/>	<input type="checkbox"/>	<input type="checkbox"/>	<input type="checkbox"/>	<input type="checkbox"/>	<input type="checkbox"/>	<input type="checkbox"/>	<input type="checkbox"/>
<b>Hair:</b>	Blow Dry	<input type="checkbox"/>	<input type="checkbox"/>	<input type="checkbox"/>	<input type="checkbox"/>	<input type="checkbox"/>	<input type="checkbox"/>	<input type="checkbox"/>	<input type="checkbox"/>
	Brush / Style	<input type="checkbox"/>	<input type="checkbox"/>	<input type="checkbox"/>	<input type="checkbox"/>	<input type="checkbox"/>	<input type="checkbox"/>	<input type="checkbox"/>	<input type="checkbox"/>
	Color	<input type="checkbox"/>	<input type="checkbox"/>	<input type="checkbox"/>	<input type="checkbox"/>	<input type="checkbox"/>	<input type="checkbox"/>	<input type="checkbox"/>	<input type="checkbox"/>
	Cut / Trim	<input type="checkbox"/>	<input type="checkbox"/>	<input type="checkbox"/>	<input type="checkbox"/>	<input type="checkbox"/>	<input type="checkbox"/>	<input type="checkbox"/>	<input type="checkbox"/>
<b>First Aid:</b>	Treating cuts and burns	<input type="checkbox"/>	<input type="checkbox"/>	<input type="checkbox"/>	<input type="checkbox"/>	<input type="checkbox"/>	<input type="checkbox"/>	<input type="checkbox"/>	<input type="checkbox"/>
<b>Hands:</b>	Apply Lotion	<input type="checkbox"/>	<input type="checkbox"/>	<input type="checkbox"/>	<input type="checkbox"/>	<input type="checkbox"/>	<input type="checkbox"/>	<input type="checkbox"/>	<input type="checkbox"/>
	Wash	<input type="checkbox"/>	<input type="checkbox"/>	<input type="checkbox"/>	<input type="checkbox"/>	<input type="checkbox"/>	<input type="checkbox"/>	<input type="checkbox"/>	<input type="checkbox"/>
<b>Medicines / Vitamins:</b>		<input type="checkbox"/>	<input type="checkbox"/>	<input type="checkbox"/>	<input type="checkbox"/>	<input type="checkbox"/>	<input type="checkbox"/>	<input type="checkbox"/>	<input type="checkbox"/>

Bathing / Showering Activities		Location			Person		
		Bathtub	Shower	Other Room	Person #1	Person #2	Person #3
Bathing:	With Someone	<input type="checkbox"/>	<input type="checkbox"/>	<input type="checkbox"/>	<input type="checkbox"/>	<input type="checkbox"/>	<input type="checkbox"/>
	Assisting an Adult	<input type="checkbox"/>	<input type="checkbox"/>	<input type="checkbox"/>	<input type="checkbox"/>	<input type="checkbox"/>	<input type="checkbox"/>
	Bathing Pets	<input type="checkbox"/>	<input type="checkbox"/>	<input type="checkbox"/>	<input type="checkbox"/>	<input type="checkbox"/>	<input type="checkbox"/>
	Soaking / Relaxing	<input type="checkbox"/>	<input type="checkbox"/>	<input type="checkbox"/>	<input type="checkbox"/>	<input type="checkbox"/>	<input type="checkbox"/>
Showering:	With Someone	<input type="checkbox"/>	<input type="checkbox"/>	<input type="checkbox"/>	<input type="checkbox"/>	<input type="checkbox"/>	<input type="checkbox"/>
	Assisting an Adult	<input type="checkbox"/>	<input type="checkbox"/>	<input type="checkbox"/>	<input type="checkbox"/>	<input type="checkbox"/>	<input type="checkbox"/>
	Steam Showering	<input type="checkbox"/>	<input type="checkbox"/>	<input type="checkbox"/>	<input type="checkbox"/>	<input type="checkbox"/>	<input type="checkbox"/>
Sauna:	Relaxing	<input type="checkbox"/>	<input type="checkbox"/>	<input type="checkbox"/>	<input type="checkbox"/>	<input type="checkbox"/>	<input type="checkbox"/>
Other:		<input type="checkbox"/>	<input type="checkbox"/>	<input type="checkbox"/>	<input type="checkbox"/>	<input type="checkbox"/>	<input type="checkbox"/>
		<input type="checkbox"/>	<input type="checkbox"/>	<input type="checkbox"/>	<input type="checkbox"/>	<input type="checkbox"/>	<input type="checkbox"/>
		<input type="checkbox"/>	<input type="checkbox"/>	<input type="checkbox"/>	<input type="checkbox"/>	<input type="checkbox"/>	<input type="checkbox"/>

Toileting Activities	Person		
	Person #1	Person #2	Person #3
Assisting an Adult:	<input type="checkbox"/>	<input type="checkbox"/>	<input type="checkbox"/>
Toileting:	<input type="checkbox"/>	<input type="checkbox"/>	<input type="checkbox"/>
Personal Cleansing:	<input type="checkbox"/>	<input type="checkbox"/>	<input type="checkbox"/>
Diaper Changing:	<input type="checkbox"/>	<input type="checkbox"/>	<input type="checkbox"/>
Reading:	<input type="checkbox"/>	<input type="checkbox"/>	<input type="checkbox"/>

Other Bathroom Activities	Location					Person		
	Vanity / Lavatory	Dressing Table	Bathtub	Shower	Other Room	Person #1	Person #2	Person #3
Display Collections	<input type="checkbox"/>	<input type="checkbox"/>	<input type="checkbox"/>	<input type="checkbox"/>	<input type="checkbox"/>	<input type="checkbox"/>	<input type="checkbox"/>	<input type="checkbox"/>
Undressing / Hamper	<input type="checkbox"/>	<input type="checkbox"/>	<input type="checkbox"/>	<input type="checkbox"/>	<input type="checkbox"/>	<input type="checkbox"/>	<input type="checkbox"/>	<input type="checkbox"/>
Dressing: Underwear / Sleep clothes	<input type="checkbox"/>	<input type="checkbox"/>	<input type="checkbox"/>	<input type="checkbox"/>	<input type="checkbox"/>	<input type="checkbox"/>	<input type="checkbox"/>	<input type="checkbox"/>
Dressing: "Street" Clothes:	<input type="checkbox"/>	<input type="checkbox"/>	<input type="checkbox"/>	<input type="checkbox"/>	<input type="checkbox"/>	<input type="checkbox"/>	<input type="checkbox"/>	<input type="checkbox"/>
Drink Beverages	<input type="checkbox"/>	<input type="checkbox"/>	<input type="checkbox"/>	<input type="checkbox"/>	<input type="checkbox"/>	<input type="checkbox"/>	<input type="checkbox"/>	<input type="checkbox"/>
Eat Snacks	<input type="checkbox"/>	<input type="checkbox"/>	<input type="checkbox"/>	<input type="checkbox"/>	<input type="checkbox"/>	<input type="checkbox"/>	<input type="checkbox"/>	<input type="checkbox"/>
Exercise w/o equipment	<input type="checkbox"/>	<input type="checkbox"/>	<input type="checkbox"/>	<input type="checkbox"/>	<input type="checkbox"/>	<input type="checkbox"/>	<input type="checkbox"/>	<input type="checkbox"/>
Exercise using equipment	<input type="checkbox"/>	<input type="checkbox"/>	<input type="checkbox"/>	<input type="checkbox"/>	<input type="checkbox"/>	<input type="checkbox"/>	<input type="checkbox"/>	<input type="checkbox"/>
Grow Plants	<input type="checkbox"/>	<input type="checkbox"/>	<input type="checkbox"/>	<input type="checkbox"/>	<input type="checkbox"/>	<input type="checkbox"/>	<input type="checkbox"/>	<input type="checkbox"/>
Laundry: Air Dry	<input type="checkbox"/>	<input type="checkbox"/>	<input type="checkbox"/>	<input type="checkbox"/>	<input type="checkbox"/>	<input type="checkbox"/>	<input type="checkbox"/>	<input type="checkbox"/>
Laundry: Hand-wash	<input type="checkbox"/>	<input type="checkbox"/>	<input type="checkbox"/>	<input type="checkbox"/>	<input type="checkbox"/>	<input type="checkbox"/>	<input type="checkbox"/>	<input type="checkbox"/>
Laundry: Machine Wash	<input type="checkbox"/>	<input type="checkbox"/>	<input type="checkbox"/>	<input type="checkbox"/>	<input type="checkbox"/>	<input type="checkbox"/>	<input type="checkbox"/>	<input type="checkbox"/>
Laundry: Sort / Fold	<input type="checkbox"/>	<input type="checkbox"/>	<input type="checkbox"/>	<input type="checkbox"/>	<input type="checkbox"/>	<input type="checkbox"/>	<input type="checkbox"/>	<input type="checkbox"/>
Listen to Music	<input type="checkbox"/>	<input type="checkbox"/>	<input type="checkbox"/>	<input type="checkbox"/>	<input type="checkbox"/>	<input type="checkbox"/>	<input type="checkbox"/>	<input type="checkbox"/>
Massage	<input type="checkbox"/>	<input type="checkbox"/>	<input type="checkbox"/>	<input type="checkbox"/>	<input type="checkbox"/>	<input type="checkbox"/>	<input type="checkbox"/>	<input type="checkbox"/>
Meditation	<input type="checkbox"/>	<input type="checkbox"/>	<input type="checkbox"/>	<input type="checkbox"/>	<input type="checkbox"/>	<input type="checkbox"/>	<input type="checkbox"/>	<input type="checkbox"/>
Personal Pampering	<input type="checkbox"/>	<input type="checkbox"/>	<input type="checkbox"/>	<input type="checkbox"/>	<input type="checkbox"/>	<input type="checkbox"/>	<input type="checkbox"/>	<input type="checkbox"/>
Exercise Equipment	<input type="checkbox"/>	<input type="checkbox"/>	<input type="checkbox"/>	<input type="checkbox"/>	<input type="checkbox"/>	<input type="checkbox"/>	<input type="checkbox"/>	<input type="checkbox"/>
Polish Shoes	<input type="checkbox"/>	<input type="checkbox"/>	<input type="checkbox"/>	<input type="checkbox"/>	<input type="checkbox"/>	<input type="checkbox"/>	<input type="checkbox"/>	<input type="checkbox"/>
Read: Books / Newspapers	<input type="checkbox"/>	<input type="checkbox"/>	<input type="checkbox"/>	<input type="checkbox"/>	<input type="checkbox"/>	<input type="checkbox"/>	<input type="checkbox"/>	<input type="checkbox"/>
Supervise Children	<input type="checkbox"/>	<input type="checkbox"/>	<input type="checkbox"/>	<input type="checkbox"/>	<input type="checkbox"/>	<input type="checkbox"/>	<input type="checkbox"/>	<input type="checkbox"/>
Talk on Telephone	<input type="checkbox"/>	<input type="checkbox"/>	<input type="checkbox"/>	<input type="checkbox"/>	<input type="checkbox"/>	<input type="checkbox"/>	<input type="checkbox"/>	<input type="checkbox"/>
Talking with People	<input type="checkbox"/>	<input type="checkbox"/>	<input type="checkbox"/>	<input type="checkbox"/>	<input type="checkbox"/>	<input type="checkbox"/>	<input type="checkbox"/>	<input type="checkbox"/>
Tanning / Sunning	<input type="checkbox"/>	<input type="checkbox"/>	<input type="checkbox"/>	<input type="checkbox"/>	<input type="checkbox"/>	<input type="checkbox"/>	<input type="checkbox"/>	<input type="checkbox"/>
Watch Television	<input type="checkbox"/>	<input type="checkbox"/>	<input type="checkbox"/>	<input type="checkbox"/>	<input type="checkbox"/>	<input type="checkbox"/>	<input type="checkbox"/>	<input type="checkbox"/>
Other:	<input type="checkbox"/>	<input type="checkbox"/>	<input type="checkbox"/>	<input type="checkbox"/>	<input type="checkbox"/>	<input type="checkbox"/>	<input type="checkbox"/>	<input type="checkbox"/>
	<input type="checkbox"/>	<input type="checkbox"/>	<input type="checkbox"/>	<input type="checkbox"/>	<input type="checkbox"/>	<input type="checkbox"/>	<input type="checkbox"/>	<input type="checkbox"/>

12. *What appliances do you plan on using in the bathroom:*

<input type="checkbox"/> Blowdryer <input type="checkbox"/> Handheld <input type="checkbox"/> Wall Mounted	<input type="checkbox"/> Electrical Toothbrush	<input type="checkbox"/> Radio/DVD/VCR	<input type="checkbox"/> Valet
	<input type="checkbox"/> Electrical Razor	<input type="checkbox"/> Television	<input type="checkbox"/> Washer & Dryer
	<input type="checkbox"/> Fireplace <input type="checkbox"/> Wood Burning <input type="checkbox"/> Gas	<input type="checkbox"/> Towel Warmer <input type="checkbox"/> Hydronic (hot water) <input type="checkbox"/> Electric	<input type="checkbox"/> Other:
<input type="checkbox"/> Curling Iron	<input type="checkbox"/> Hot Rollers	<input type="checkbox"/> Scale	<input type="checkbox"/> Other:

# Storage Checklist

Item	User		Type of Equipment	Shelf / Drawer Space Required
Make-up Storage	(person #1)	<input type="checkbox"/> Yes <input type="checkbox"/> No		
	(person #2)	<input type="checkbox"/> Yes <input type="checkbox"/> No		
Shaving Storage	(person #1)	<input type="checkbox"/> Yes <input type="checkbox"/> No		
	(person #2)	<input type="checkbox"/> Yes <input type="checkbox"/> No		
Hair Grooming Equipment	(person #1)	<input type="checkbox"/> Yes <input type="checkbox"/> No		
	(person #2)	<input type="checkbox"/> Yes <input type="checkbox"/> No		
Hand and Foot Grooming Equip	(person #1)	<input type="checkbox"/> Yes <input type="checkbox"/> No		
	(person #2)	<input type="checkbox"/> Yes <input type="checkbox"/> No		
Personal Hygiene Equipment	(person #1)	<input type="checkbox"/> Yes <input type="checkbox"/> No		
	(person #2)	<input type="checkbox"/> Yes <input type="checkbox"/> No		
Medicine / First Aid		<input type="checkbox"/> Yes <input type="checkbox"/> No		
Bathroom Paper Product Storage		<input type="checkbox"/> Yes <input type="checkbox"/> No		
Bath Towel Storage		<input type="checkbox"/> Yes <input type="checkbox"/> No		
Household Bedroom Linen		<input type="checkbox"/> Yes <input type="checkbox"/> No		
Personal Pampering Equip	(person #1)	<input type="checkbox"/> Yes <input type="checkbox"/> No		
	(person #2)	<input type="checkbox"/> Yes <input type="checkbox"/> No		
	(person #3)	<input type="checkbox"/> Yes <input type="checkbox"/> No		
	(person #4)	<input type="checkbox"/> Yes <input type="checkbox"/> No		
Exercise Equipment	(person #1)	<input type="checkbox"/> Yes <input type="checkbox"/> No		
	(person #2)	<input type="checkbox"/> Yes <input type="checkbox"/> No		
	(person #3)	<input type="checkbox"/> Yes <input type="checkbox"/> No		
	(person #4)	<input type="checkbox"/> Yes <input type="checkbox"/> No		
Pet Grooming / Bathing Area		<input type="checkbox"/> Yes <input type="checkbox"/> No		
Cleaning Supply Storage		<input type="checkbox"/> Yes <input type="checkbox"/> No		
Shoe Polishing Paraphernalia		<input type="checkbox"/> Yes <input type="checkbox"/> No		
Other	Hanging	<input type="checkbox"/> Yes <input type="checkbox"/> No	Shelf Length: _____	Double Pole: <input type="checkbox"/> Single Pole: <input type="checkbox"/>
	Shoes	# of Pairs _____	Boxed: <input type="checkbox"/> Yes <input type="checkbox"/> No	Shelf Length: _____
	Folded Clothing	# of Drawers / Pull-outs _____		
	Accessories	<input type="checkbox"/> Yes <input type="checkbox"/> No	Types: _____	Wall Space for Racks: _____
	Hats	Rack: <input type="checkbox"/> Yes <input type="checkbox"/> No	Boxes: <input type="checkbox"/> Yes <input type="checkbox"/> No	Shelf Space: _____
	Full Length Mirror	<input type="checkbox"/> Yes <input type="checkbox"/> No		
Other	Hanging	<input type="checkbox"/> Yes <input type="checkbox"/> No	Shelf Length: _____	Double Pole: <input type="checkbox"/> Single Pole: <input type="checkbox"/>
	Shoes	# of Pairs _____	Boxed: <input type="checkbox"/> Yes <input type="checkbox"/> No	Shelf Length: _____
	Folded Clothing	# of Drawers: _____		
	Accessories	<input type="checkbox"/> Yes <input type="checkbox"/> No	Types: _____	
	Hats	Rack: <input type="checkbox"/> Yes <input type="checkbox"/> No	Boxes: <input type="checkbox"/> Yes <input type="checkbox"/> No	
	Full Length Mirror	<input type="checkbox"/> Yes <input type="checkbox"/> No		

## Storage Checklist (Continued)

Laundry Facilities	<input type="checkbox"/> Yes <input type="checkbox"/> No	Equipment Size:
Mini Kitchen	<input type="checkbox"/> Yes <input type="checkbox"/> No	What Type of Equipment? <input type="checkbox"/> Bar Sink <input type="checkbox"/> Coffeemaker <input type="checkbox"/> Cooktop <input type="checkbox"/> Microwave <input type="checkbox"/> Refrigerator <input type="checkbox"/> Other: _____ <input type="checkbox"/> Other: _____
Other:		

## Design Information

1. *What type of feeling would you like your new bathroom space to have? Have you created a scrapbook of notes, photos and ideas of bathrooms that you like?*

- American Country     
  Asian / Warm Contemporary     
  Old World European     
  Sleek Contemporary  
 American Formal     
  Craftsman / Arts and Crafts     
  Personal Design Statement (Eclectic)     
  Traditional

---

---

---

---

---

2. *What colors do you like?* \_\_\_\_\_  
*And dislike?* \_\_\_\_\_  
*What colors are you considering for you new bathroom?* \_\_\_\_\_  
*What are the color preferences of other family members?* \_\_\_\_\_

3. *Are there specific materials, fixtures, cabinetry or other features that you have pre-selected and want included in the project?* \_\_\_\_\_

---

---

---

---

---

4. *Design Notes:* \_\_\_\_\_

---

---

---

---

---

Special Details:

Cabinetry				Source					
Key: BS= Bath Specialist O= Owner OA= Owners Agent				Use Existing <input type="checkbox"/> Yes <input type="checkbox"/> No		Furnished by BS <input type="checkbox"/> O/OA <input type="checkbox"/>		Installed by BS <input type="checkbox"/> O/OA <input type="checkbox"/>	
Style	Base	Wall	Tall	Face Material		Base	Wall	Tall	
Furniture (Unfitted)	<input type="checkbox"/>	<input type="checkbox"/>	<input type="checkbox"/>	Wood-Species		<input type="checkbox"/>	<input type="checkbox"/>	<input type="checkbox"/>	
Built-In (Fitted)	<input type="checkbox"/>	<input type="checkbox"/>	<input type="checkbox"/>	Laminate		<input type="checkbox"/>	<input type="checkbox"/>	<input type="checkbox"/>	
Construction				Paint		<input type="checkbox"/>	<input type="checkbox"/>	<input type="checkbox"/>	
Framed	<input type="checkbox"/>	<input type="checkbox"/>	<input type="checkbox"/>	Acrylic		<input type="checkbox"/>	<input type="checkbox"/>	<input type="checkbox"/>	
Frameless	<input type="checkbox"/>	<input type="checkbox"/>	<input type="checkbox"/>	Metal		<input type="checkbox"/>	<input type="checkbox"/>	<input type="checkbox"/>	
Door Type				Other: _____		<input type="checkbox"/>	<input type="checkbox"/>	<input type="checkbox"/>	
Full Overlay	<input type="checkbox"/>	<input type="checkbox"/>	<input type="checkbox"/>	Door Style		<input type="checkbox"/>	<input type="checkbox"/>	<input type="checkbox"/>	
Partial Overlay	<input type="checkbox"/>	<input type="checkbox"/>	<input type="checkbox"/>			<input type="checkbox"/>	<input type="checkbox"/>	<input type="checkbox"/>	
Lip	<input type="checkbox"/>	<input type="checkbox"/>	<input type="checkbox"/>			<input type="checkbox"/>	<input type="checkbox"/>	<input type="checkbox"/>	
Inset	<input type="checkbox"/>	<input type="checkbox"/>	<input type="checkbox"/>			<input type="checkbox"/>	<input type="checkbox"/>	<input type="checkbox"/>	
Hardware				Color and Finish		<input type="checkbox"/>	<input type="checkbox"/>	<input type="checkbox"/>	
Knob	<input type="checkbox"/>	<input type="checkbox"/>	<input type="checkbox"/>			<input type="checkbox"/>	<input type="checkbox"/>	<input type="checkbox"/>	
Pull	<input type="checkbox"/>	<input type="checkbox"/>	<input type="checkbox"/>			<input type="checkbox"/>	<input type="checkbox"/>	<input type="checkbox"/>	
Finger Pull	<input type="checkbox"/>	<input type="checkbox"/>	<input type="checkbox"/>			<input type="checkbox"/>	<input type="checkbox"/>	<input type="checkbox"/>	
Material	<input type="checkbox"/>	<input type="checkbox"/>	<input type="checkbox"/>			<input type="checkbox"/>	<input type="checkbox"/>	<input type="checkbox"/>	

Soffit / Fascia					
Use Existing <input type="checkbox"/> Yes <input type="checkbox"/> No		Furnished by BS <input type="checkbox"/> O/OA <input type="checkbox"/>		Installed by BS <input type="checkbox"/> O/OA <input type="checkbox"/>	
Fascia / Soffit Construction			Fascia / Soffit Materials		
<input type="checkbox"/> Open <input type="checkbox"/> Extended <input type="checkbox"/> Flush <input type="checkbox"/> Recessed <input type="checkbox"/> Remove			<input type="checkbox"/> Wallpaper <input type="checkbox"/> Wood <input type="checkbox"/> Display Rail <input type="checkbox"/> Paint <input type="checkbox"/> Lighted		
<input type="checkbox"/> Other: _____			<input type="checkbox"/> Cornice <input type="checkbox"/> Other: _____		

Surfaces					Source					
Key: BS= Bath Specialist O= Owner OA= Owners Agent					Use Existing <input type="checkbox"/> Yes <input type="checkbox"/> No		Furnished by BS <input type="checkbox"/> O/OA <input type="checkbox"/>		Installed by BS <input type="checkbox"/> O/OA <input type="checkbox"/>	
Material	Vanity	Shower Walls	Tub Platform	Other	Edge Treatment	Vanity	Shower Walls	Tub Platform	Other	
Concrete	<input type="checkbox"/>	<input type="checkbox"/>	<input type="checkbox"/>		Thickness					
Cultured Marble	<input type="checkbox"/>	<input type="checkbox"/>	<input type="checkbox"/>		Shape:					
Decorative Laminate	<input type="checkbox"/>	<input type="checkbox"/>	<input type="checkbox"/>		Bevel	<input type="checkbox"/>	<input type="checkbox"/>	<input type="checkbox"/>		
Engineered Stone (Quartz)	<input type="checkbox"/>	<input type="checkbox"/>	<input type="checkbox"/>		Ogee	<input type="checkbox"/>	<input type="checkbox"/>	<input type="checkbox"/>		
Granite	<input type="checkbox"/>	<input type="checkbox"/>	<input type="checkbox"/>		Bull Nose Full	<input type="checkbox"/>	<input type="checkbox"/>	<input type="checkbox"/>		
Marble	<input type="checkbox"/>	<input type="checkbox"/>	<input type="checkbox"/>		½ Full	<input type="checkbox"/>	<input type="checkbox"/>	<input type="checkbox"/>		
Solid Surface	<input type="checkbox"/>	<input type="checkbox"/>	<input type="checkbox"/>		Square	<input type="checkbox"/>	<input type="checkbox"/>	<input type="checkbox"/>		
Tile	<input type="checkbox"/>	<input type="checkbox"/>	<input type="checkbox"/>		Other:					
Size					Backsplash					
Grout					Height					
Wood	<input type="checkbox"/>	<input type="checkbox"/>	<input type="checkbox"/>		End Splash Sides					
Other Stone:					Countertop ext. over Water Closet					
Special Notes					Special Notes					

### Bath Fixtures & Fittings - Water Closet

Use Existing <input type="checkbox"/> Yes <input type="checkbox"/> No	Furnished by		Installed by	
	BS <input type="checkbox"/>	O/OA <input type="checkbox"/>	BS <input type="checkbox"/>	O/OA <input type="checkbox"/>
<input type="checkbox"/> 1 Piece Low Profile	<input type="checkbox"/> 2 Piece Standard Height		Color:	
<input type="checkbox"/> Wall Hung	<input type="checkbox"/> Elongated Seat		Seat:	
<input type="checkbox"/> Round Seat	<input type="checkbox"/> Other		Trip Lever Finish:	
<input type="checkbox"/> Comfort Height	<input type="checkbox"/> Other		Stop & Supply Finish:	

### Bath Fixtures & Fittings - Bidet / Bidet Seat

Use Existing <input type="checkbox"/> Yes <input type="checkbox"/> No	Furnished by		Installed by	
	BS <input type="checkbox"/>	O/OA <input type="checkbox"/>	BS <input type="checkbox"/>	O/OA <input type="checkbox"/>
<input type="checkbox"/> Vertical Spray Vacuum Breaker	Color:		Other:	
<input type="checkbox"/> Horizontal Spray	Faucet Finish:		Other:	

### Bath Fixtures & Fittings - Bathtub

Use Existing <input type="checkbox"/> Yes <input type="checkbox"/> No	Furnished by				Installed by				
	BS <input type="checkbox"/>		O/OA <input type="checkbox"/>		BS <input type="checkbox"/>		O/OA <input type="checkbox"/>		
<b>Material</b>					<b>Placement</b>				
<input type="checkbox"/> Cast Iron	<input type="checkbox"/> Fiberglass	<input type="checkbox"/> Ceramic Tile	<input type="checkbox"/> Cult Marble		<input type="checkbox"/> Left Drain			<input type="checkbox"/> Right Drain	
<input type="checkbox"/> Steel	<input type="checkbox"/> Acrylic	<input type="checkbox"/> _____	<input type="checkbox"/> _____		<b>Fitting #1</b>				
<b>Configuration</b>					Type:	Finish:	Location:		
<input type="checkbox"/> Platform	<input type="checkbox"/> Skirted	<input type="checkbox"/> Platform w/ Steps	<input type="checkbox"/> Free Standing		<b>Fitting #2</b>				
					Type:	Finish:	Location:		

### Bath Fixtures & Fittings - Shower

Use Existing <input type="checkbox"/> Yes <input type="checkbox"/> No	Furnished by				Installed by				
	BS <input type="checkbox"/>		O/OA <input type="checkbox"/>		BS <input type="checkbox"/>		O/OA <input type="checkbox"/>		
<b>Fabricated</b>					<b>Fittings</b>				
<input type="checkbox"/> 1 Piece		<input type="checkbox"/> Multiple Piece			Shower #1	Valve Type:	Head Type:	Finish:	
<b>Custom</b>					Shower #2	Valve Type:	Head Type:	Finish:	
Shower Wall Material:		Shower Floor/ Pan Material:		Shower #3	Valve Type:	Head Type:	Finish:		
Height:				Shower #4- Body Sprays		Finish:			
				Shower #5- Hand-Held		Finish:			
				Diverter		Finish:			
<b>Configuration</b>									
Drain	Finish:				Grooming	Recess:		Size:	
Bench	Size:				Other				

## Bath Fixtures & Fittings - Lavatory

<b>Use Existing</b> <input type="checkbox"/> Yes <input type="checkbox"/> No		<b>Furnished by</b>		<b>Installed by</b>	
		BS <input type="checkbox"/>	O/OA <input type="checkbox"/>	BS <input type="checkbox"/>	O/OA <input type="checkbox"/>
<b>Material</b>				<b>Fittings</b>	
<input type="checkbox"/> Porcelain	<input type="checkbox"/> Glass	<input type="checkbox"/> Cast Iron	<input type="checkbox"/> _____	<input type="checkbox"/> 4" Centers	<input type="checkbox"/> 8" Centers
<input type="checkbox"/> Stainless Steel	<input type="checkbox"/> Decorative Metal	<input type="checkbox"/> Composition	<input type="checkbox"/> _____	<input type="checkbox"/> Single Hole	<input type="checkbox"/> Wall Mounted
<b>Configuration</b>				<b>Finish</b>	
<input type="checkbox"/> Pedestal/Trap Cover	<input type="checkbox"/> Rimmed	<input type="checkbox"/> Under-Counter	<input type="checkbox"/> Wall Hung	<input type="checkbox"/> _____	
<input type="checkbox"/> Vessel	<input type="checkbox"/> Self-Rimmed	<input type="checkbox"/> Integral	<input type="checkbox"/> Other: _____	<input type="checkbox"/> _____	

## Ventilation

<b>Use Existing</b> <input type="checkbox"/> Yes <input type="checkbox"/> No		<b>Furnished by</b>		<b>Installed by</b>	
		BS <input type="checkbox"/>	O/OA <input type="checkbox"/>	BS <input type="checkbox"/>	O/OA <input type="checkbox"/>
<input type="checkbox"/> Fan	<input type="checkbox"/> Fan, Light (Combo)	<input type="checkbox"/> Fan, Light, Heat (Combo)		<input type="checkbox"/> Switch	<input type="checkbox"/> Timer
CFM Capacity:			Duct Work Space:		

## Heating

<b>Use Existing</b> <input type="checkbox"/> Yes <input type="checkbox"/> No		<b>Furnished by</b>		<b>Installed by</b>	
		BS <input type="checkbox"/>	O/OA <input type="checkbox"/>	BS <input type="checkbox"/>	O/OA <input type="checkbox"/>
<input type="checkbox"/> Auxiliary	<input type="checkbox"/> Timer	Placement:			
<input type="checkbox"/> Switch					

## Enclosures (Steam Door/s, Shower, Doors, Drapes, Etc.)

<b>Use Existing</b> <input type="checkbox"/> Yes <input type="checkbox"/> No		<b>Furnished by</b>		<b>Installed by</b>	
		BS <input type="checkbox"/>	O/OA <input type="checkbox"/>	BS <input type="checkbox"/>	O/OA <input type="checkbox"/>
<b>Tub</b>	Finish:	Size:	Type:	Material:	
<b>Shower</b>	Finish:	Size:	Type:	Material:	
<b>Steam</b>	Finish:	Size:	Type:	Material:	
<b>Sauna</b>	Finish:	Size:	Type:	Material:	
Curtain Rod Finish:		Size:	Curtains (Color)		Size:

## Light Fixtures

<b>Use Existing</b> <input type="checkbox"/> Yes <input type="checkbox"/> No		<b>Furnished by</b>		<b>Installed by</b>	
		BS <input type="checkbox"/>	O/OA <input type="checkbox"/>	BS <input type="checkbox"/>	O/OA <input type="checkbox"/>
<b>General</b>				<b>Ambient</b>	
<input type="checkbox"/> Incandescent	<input type="checkbox"/> Halogen	<input type="checkbox"/> Fluorescent	<input type="checkbox"/> Xenon	<input type="checkbox"/> Cove	<input type="checkbox"/> Recessed
				<input type="checkbox"/> Pendant	<input type="checkbox"/> Surface Mounted
<b>Decorative</b>				<input type="checkbox"/> Track	<input type="checkbox"/> Incandescent
				<input type="checkbox"/> Halogen	<input type="checkbox"/> Fluorescent
<input type="checkbox"/> Incandescent				<b>Special Details</b>	
<input type="checkbox"/> Halogen					
<input type="checkbox"/> Fluorescent					
<input type="checkbox"/> Xenon					

Task Lighting			
<input type="checkbox"/> Incandescent	<input type="checkbox"/> Halogen	<input type="checkbox"/> Fluorescent	<input type="checkbox"/> Xenon

## Accessories

Use Existing <input type="checkbox"/> Yes <input type="checkbox"/> No	Furnished by		Installed by	
	BS <input type="checkbox"/>	O/OA <input type="checkbox"/>	BS <input type="checkbox"/>	O/OA <input type="checkbox"/>
Glass Shelves	Qty:	Support:	Size:	
	Finish:	Edge Treatment:		
Medicine Cabinet	Qty:	<input type="checkbox"/> Surface Mount <input type="checkbox"/> Recessed	Size: <input type="checkbox"/>	
	Finish:	Mirror Size: <input type="checkbox"/>		
Mirror	Qty:	<input type="checkbox"/> Surface Mount <input type="checkbox"/> Frame		
Towel Bars	Qty:	Finish:	Size:	No:
Towel Rings	Qty:	Finish:	Size:	No:
Robe Hooks	Qty:	Finish:	Size:	No:
Tub Soap Dish	Qty:	<input type="checkbox"/> Surface Mount <input type="checkbox"/> Recessed	Finish:	Placement:
Shower Soap Dish	Qty:	<input type="checkbox"/> Surface Mount <input type="checkbox"/> Recessed	Finish:	Placement:
Bidet Soap Dish	Qty:	<input type="checkbox"/> Surface Mount <input type="checkbox"/> Recessed	Finish:	Placement:
Lavatory Soap Dish	Qty:	<input type="checkbox"/> Surface Mount <input type="checkbox"/> Recessed	Finish:	Placement:
Tub Grab Bars	Qty:	Finish:	Placement:	
Toilet Grab Bars	Qty:	Finish:	Placement:	
Paper Holder	Qty:	<input type="checkbox"/> Surface Mount <input type="checkbox"/> Recessed	Finish:	Placement:
Magazine Rack	Qty:	<input type="checkbox"/> Surface Mount <input type="checkbox"/> Recessed	Finish:	Placement:
Soap/Lotion Dispenser	Qty:	Finish:	Placement:	
Tumbler Holder	Qty:	Finish:	Placement:	
Toothbrush Holder	Qty:	Finish:	Placement:	
TV	Qty:	Finish:	Placement:	

## Sauna

Use Existing <input type="checkbox"/> Yes <input type="checkbox"/> No	Furnished by		Installed by	
	BS <input type="checkbox"/>	O/OA <input type="checkbox"/>	BS <input type="checkbox"/>	O/OA <input type="checkbox"/>
Capacity:	Interior:	Style:	Heater:	
Timer Location:	Wall Material:	Floor Material:	Other:	

## Steam Bath

Use Existing <input type="checkbox"/> Yes <input type="checkbox"/> No	Furnished by		Installed by	
	BS <input type="checkbox"/>	O/OA <input type="checkbox"/>	BS <input type="checkbox"/>	O/OA <input type="checkbox"/>
<input type="checkbox"/> Tub <input type="checkbox"/> Shower	Steam Generator Location:	Timer Location:	Wall Material:	Floor Material:

## Exercise Equipment

Treadmill	Size:	Clearance Required: 30 sq. ft.
Free Weights	Size:	Clearance Required: 20-30 sq. ft.
Bikes, Recumbent & Upright	Size:	Clearance Required: 10 sq. ft.
Rowing Machines	Size:	Clearance Required: 20 sq. ft.
Stair Climbers	Size:	Clearance Required: 10 to 20 sq. ft.
Ski Machines	Size:	Clearance Required: 25 sq. ft.
Single-Station Gym	Size:	Clearance Required: 35 sq. ft.
Multi-Station Gym	Size:	Clearance Required: 50 to 200 sq. ft.
Yoga Matte	Size:	Clearance Required:

## Flooring

Use Existing <input type="checkbox"/> Yes <input type="checkbox"/> No	Furnished by		Installed by	
	BS <input type="checkbox"/>	O/OA <input type="checkbox"/>	BS <input type="checkbox"/>	O/OA <input type="checkbox"/>
<b>Floor Preparation</b>		<b>Floor Covering</b>		
<input type="checkbox"/> Removal:		<b>Material</b>		
<input type="checkbox"/> Leveling:		<input type="checkbox"/> Bamboo	<input type="checkbox"/> Carpet	<input type="checkbox"/> Ceramic Tile
<input type="checkbox"/> Shim:		<input type="checkbox"/> Laminate	<input type="checkbox"/> Linoleum	<input type="checkbox"/> Vinyl-Sheet
<input type="checkbox"/> Subfloor Material:		<input type="checkbox"/> Wood	<input type="checkbox"/> Wood-Engineered	<input type="checkbox"/> Stone
<input type="checkbox"/> Underlayment:		<input type="checkbox"/> Other		
<input type="checkbox"/> Baseboard:		<b>Color or Pattern:</b>		
<input type="checkbox"/> Transition Treatment		Describe:		

## Windows

Check all that apply.  
 Slider = S Casement = C Double-Hung = DH Skylight = SL Bow = BO Bay = BA  
 Vinyl = V Aluminum = A Aluminum Clad = AC Wood = W Glass Block = GB

Use Existing <input type="checkbox"/> Yes <input type="checkbox"/> No	Furnished by		Installed by	
	KS <input type="checkbox"/>	O/OA <input type="checkbox"/>	KS <input type="checkbox"/>	O/OA <input type="checkbox"/>
Interior Wall Patch:		Exterior Wall Patch:		Sink Vent Relocation:
Window #	Configuration	New Windows Sizes		
				Screen: <input type="checkbox"/> Yes <input type="checkbox"/> No
				Screen: <input type="checkbox"/> Yes <input type="checkbox"/> No
				Screen: <input type="checkbox"/> Yes <input type="checkbox"/> No
				Screen: <input type="checkbox"/> Yes <input type="checkbox"/> No
				Screen: <input type="checkbox"/> Yes <input type="checkbox"/> No
				Screen: <input type="checkbox"/> Yes <input type="checkbox"/> No

Doors		Check all that apply.			
		Bi-Fold = BF	Slider = S	Pocket = P	French = F
		Solid Core = SC		Steel = ST	Hollow Core = HC
<input type="checkbox"/> Yes <input type="checkbox"/> No		Furnished by		Installed by	
		KS <input type="checkbox"/>	O/OA <input type="checkbox"/>	KS <input type="checkbox"/>	O/OA <input type="checkbox"/>
Door #	Configuration	Hinge	Size		Screen
		<input type="checkbox"/> Yes <input type="checkbox"/> No			Screen: <input type="checkbox"/> Yes <input type="checkbox"/> No
		<input type="checkbox"/> Yes <input type="checkbox"/> No			Screen: <input type="checkbox"/> Yes <input type="checkbox"/> No
		<input type="checkbox"/> Yes <input type="checkbox"/> No			Screen: <input type="checkbox"/> Yes <input type="checkbox"/> No
		<input type="checkbox"/> Yes <input type="checkbox"/> No			Screen: <input type="checkbox"/> Yes <input type="checkbox"/> No
		<input type="checkbox"/> Yes <input type="checkbox"/> No			Screen: <input type="checkbox"/> Yes <input type="checkbox"/> No
		<input type="checkbox"/> Yes <input type="checkbox"/> No			Screen: <input type="checkbox"/> Yes <input type="checkbox"/> No
		<input type="checkbox"/> Yes <input type="checkbox"/> No			Screen: <input type="checkbox"/> Yes <input type="checkbox"/> No
Hardware Finish:			<input type="checkbox"/> Passage <input type="checkbox"/> Privacy <input type="checkbox"/> Knob <input type="checkbox"/> Lever		

Decorative Surfaces						
Use Existing		Furnished by			Installed by	
		<input type="checkbox"/> Yes <input type="checkbox"/> No		BS <input type="checkbox"/>	O/OA <input type="checkbox"/>	BS <input type="checkbox"/>
Wall Preparation	<input type="checkbox"/> New Plaster/Drywall	<input type="checkbox"/> Clean	<input type="checkbox"/> Patch Exist	<input type="checkbox"/> Remove Exist. Covering:		
Wall Finish	<input type="checkbox"/> New Plaster/Drywall	<input type="checkbox"/> Clean	<input type="checkbox"/> Patch Exist	<input type="checkbox"/> Remove Exist. Covering:		
Ceiling Finish	<input type="checkbox"/> Paint	<input type="checkbox"/> Wallpaper	<input type="checkbox"/> Suspended	<input type="checkbox"/> Vaulted	<input type="checkbox"/> Other: _____	
Ceiling Preparation	<input type="checkbox"/> New Plaster / Drywall	<input type="checkbox"/> Clean	<input type="checkbox"/> Patch Exist	<input type="checkbox"/> Remove Existing Covering		
	Other: _____		Repairs: _____			
Window Treatment	<input type="checkbox"/> Blinds	<input type="checkbox"/> Fabric	<input type="checkbox"/> Shutters	Other: _____		

Construction	Source			Category
	Use Existing	Responsibility		
		BS	O / OA	
HVAC Details:	<input type="checkbox"/>	<input type="checkbox"/>	<input type="checkbox"/>	Air Conditioning System Age: _____ Planned Improvements: _____ _____ Heating System Age: _____ Planned Improvements: _____ _____ Bathroom Exhaust Fan Age: _____ Planned Improvements: _____ _____
Electrical Work:	<input type="checkbox"/>	<input type="checkbox"/>	<input type="checkbox"/>	New Service Panel: _____ Code Updates: _____ Modifications to Exist. Service: _____ Heated Floor: <input type="checkbox"/> Yes <input type="checkbox"/> No Heated Towel Bar: <input type="checkbox"/> Yes <input type="checkbox"/> No
Plumbing:	<input type="checkbox"/>	<input type="checkbox"/>	<input type="checkbox"/>	New Rough-In Requirements: _____ New Drainage Requirements: _____ New Vent Stack Requirements: _____ Modifications to Exist. Lines: _____
General Carpentry:	<input type="checkbox"/>	<input type="checkbox"/>	<input type="checkbox"/>	<b>Demolition Work</b> Exist. Fixture and Equip. Removal: _____ Trash Removal: _____ <b>Reconstruction Work (Except as previously noted.)</b> Widows: _____ Doors: _____ Interior Walls: _____ Exterior Walls: _____ Insulated: _____ Cabinet Install. / Trim-Out: _____
Miscellaneous Work:	<input type="checkbox"/>	<input type="checkbox"/>	<input type="checkbox"/>	Jobsite / Room Clean-up: _____ Building Permits: _____ Structural Engineering / Architectural Fees: _____ Inspection Fees: _____ Jobsite Delivery: _____ Other: _____

## Existing Construction Details

1. *Age of Home:* \_\_\_\_\_ *Access Roads to Home:* \_\_\_\_\_  
*Delivery Truck Clearances:* \_\_\_\_\_ *Elevator Size Limitations:* \_\_\_\_\_  
*Access to Bath:*  Through House  Exterior Access

2. *Type of Neighborhood:*  
 Rural  Suburban  Urban  Historic  Mixed Use  Multi-Family  Gated Community  Planned Development

3. *Type of Home:*  
 Single Family  Duplex  Townhouse  Condominium  Apartment / Flat  Other: \_\_\_\_\_

4. *Structure of Home:*  
 One Story  Two-Story  Three-Story  Ranch  Split-Level  Split-Foyer/Raised Ranch  Other: \_\_\_\_\_

5. *Approximate Size of Home:* \_\_\_\_\_

6. *Style of Home (Exterior):* \_\_\_\_\_

7. *Is the home historic?*  Yes  No What time period? \_\_\_\_\_  
Are there historic covenants or restrictions affecting the home? \_\_\_\_\_  
\_\_\_\_\_

8. *Is the home part of a Homeowner's Association?*  Yes  No  
Are there Homeowner's Association covenants or restrictions affecting the home?  Yes  No \_\_\_\_\_  
\_\_\_\_\_

9. *Style of Home (Interior)*  
Colors: \_\_\_\_\_  
Materials: \_\_\_\_\_  
Furniture: \_\_\_\_\_  
Accessories: \_\_\_\_\_  
Other: \_\_\_\_\_  
\_\_\_\_\_  
\_\_\_\_\_

10. *Room Below Bathroom* \_\_\_\_\_ *Room Above Bathroom* \_\_\_\_\_

## Existing Construction Details- continued

11. **Condition of**–

Surface Walls \_\_\_\_\_

Floors: \_\_\_\_\_

Ceilings: \_\_\_\_\_

Soffit/Fascia: \_\_\_\_\_

Squareness of Corners: \_\_\_\_\_ Parallel Wall to Within  $\frac{3}{4}$ ) \_\_\_\_\_

**Is there any hazardous material to be removed?** \_\_\_\_\_

12. **Construction of Floor:**  Slab  Frame

13. **Direction of Floor Joists:**  Parallel to Longest Bathroom Wall  Perpendicular to Bathroom Longest Wall Joist Height: \_\_\_\_\_

14. **Exterior:**  Brick  Aluminum  Stucco  Wood  Other: \_\_\_\_\_

15. **Interior:**  Drywall  Lath & Plaster  Wood  Other: \_\_\_\_\_

16. **Windows Can Be Changed:**  Yes  No Doors Can Be Relocated:  Yes  No Walls Can Be Relocated:  Yes  No

17. **Windows:**  Sliders  Double-Hung  Skylights  Casement  Greenhouse  Bow/Bay  Other: \_\_\_\_\_

18. **Sewage System:**  City Service  Septic System  Other: \_\_\_\_\_

19. **Type of Roof Material:** \_\_\_\_\_ **Age of Roof** \_\_\_\_\_

**Access:**

Can Equipment Fit Into The Room? \_\_\_\_\_

Basement: \_\_\_\_\_ Attic: \_\_\_\_\_ Crawl Space: \_\_\_\_\_

Material Storage: \_\_\_\_\_ Trash Collection Area: \_\_\_\_\_

HVAC: Describe Existing System: Heating: \_\_\_\_\_ Ventilation: \_\_\_\_\_ Air Conditioning: \_\_\_\_\_

**Plumbing:**

Location of Existing Vent Stack: \_\_\_\_\_ Type of Trap: \_\_\_\_\_

Add Additional Line: \_\_\_\_\_

**Electrical**

GFCI Existing:  Yes  No

New Wiring Access:  Hard  Average  Easy Number of Open Circuits for Expansion: \_\_\_\_\_

Existing Electrical Service Capacity: \_\_\_\_\_ Number of 120V Circuits: \_\_\_\_\_ Number of 240V Circuits: \_\_\_\_\_

# Existing Plumbing Center Lines

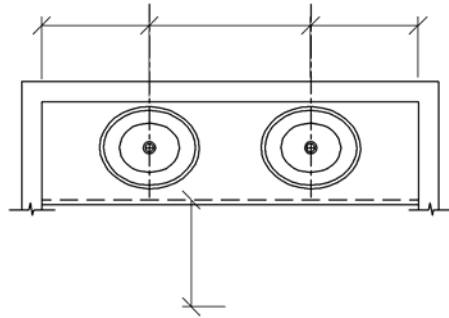
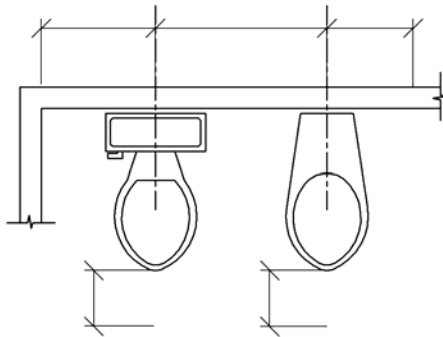
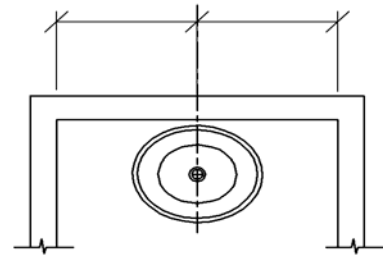
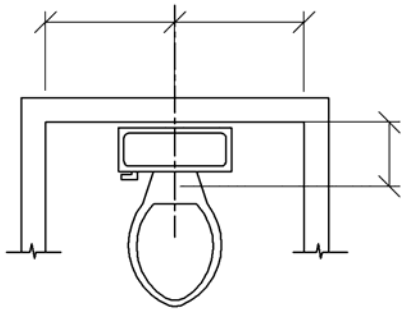

Water Closet  
 Width: \_\_\_\_\_  
 Height: \_\_\_\_\_  
 Depth: \_\_\_\_\_  
 Type of W.C.: Wall Hung  2 Piece  1 Piece   
 Wall Hung: Width: \_\_\_\_\_ Height: \_\_\_\_\_  
 Distance Tank for Walls: \_\_\_\_\_  
 Soil Stack Location: \_\_\_\_\_  
 Water Supply Height: \_\_\_\_\_ Of Floor: \_\_\_\_\_

Lavatory  
 Water Supply: Floor  Wall   
 Drain out of: Floor  Wall   
 Bottom of Trap to Floor: \_\_\_\_\_  
 Type of Lavatory: Wall Hung  In Vanity  Pedestal   
 Wall Mount: Width: \_\_\_\_\_ Height: \_\_\_\_\_  
 Vanity: Width: \_\_\_\_\_ Height: \_\_\_\_\_ Depth: \_\_\_\_\_  
 Vent Pipe Location: \_\_\_\_\_

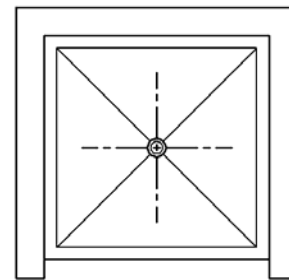
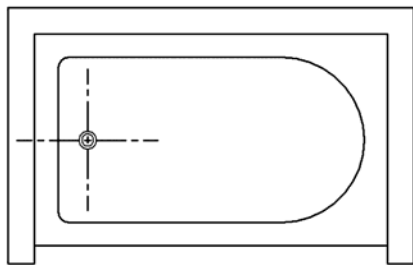

Tub  
 Width: \_\_\_\_\_  
 Height: \_\_\_\_\_  
 Depth: \_\_\_\_\_  
 Tub/Shower Material: Cast Iron  Steel  Fiberglass  Other   
 Tub/Shower Surround: Yes  No   
 Surround Material: Tub \_\_\_\_\_ Shower \_\_\_\_\_  
 Surround With: \_\_\_\_\_ Height: \_\_\_\_\_ Width: \_\_\_\_\_  
 Shower Stub Out Height: \_\_\_\_\_  
 Plumbing Access Below: Yes  No   
 Type of Drain: Cast Iron  Copper  Plastic   
 Type of Trap: Drum  P   
 Bathroom on: First Floor  Second Floor  Other  \_\_\_\_\_





Register or Fan							
No.	A	B	C	D	E	F	G

